

AIRLAY RECTANGULAR ATTENUATORS

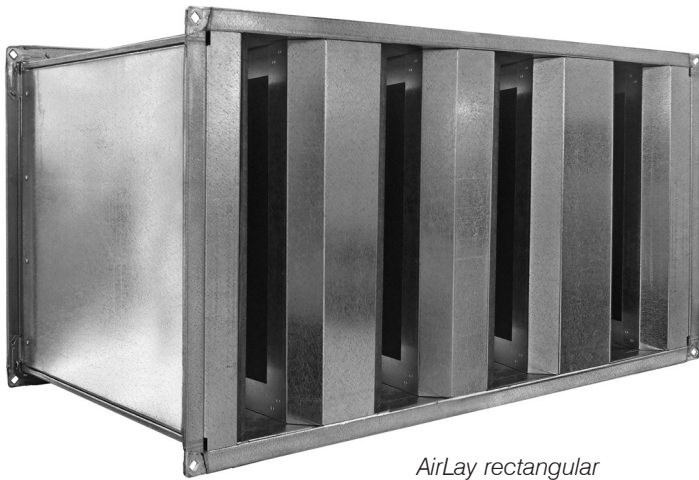

AirLay rectangular attenuator



AirLay splitter section

DESCRIPTION

The patented AirLay range of rectangular attenuators achieves superior noise reduction in commercial HVAC applications. Its revolutionary polyester acoustic infill provides greater insertion losses across the most critical frequencies when compared to conventional infill materials. This high performance infill is made from 70% recycled plastic and features a hardened outer membrane which reduces the potential for insulation fibres to enter the airstream.

Standard lengths available from 600 to 3000mm or manufactured to individual requirements.

Features

- Engineered design to reduce the overall weight and improve performance.
- Patented design including AirLay polyester acoustic infill that provides greater insertion losses across the most critical frequencies.
- Infill features a hardened outer membrane to reduce the potential for insulation fibres to enter the airstream.
- Straight splitters will provide higher noise reductions.
- Tapered splitters will give lower pressure drops.

Typical Applications

Used in general HVAC applications where high insertion losses are required. This range is suitable for temperatures up to 80 °C and for dry applications. For applications where water may be present in the air stream or where insulation must be encapsulated refer to the Q-Seal attenuator series (page H4).

CONSTRUCTION

- Casing and splitter frames made from Z275 coated galvanised sheet metal as standard or stainless steel as a special order.
- Polyester acoustic infill is made from 70% recycled plastic with a hardened membrane facing.
- Standard construction rated to duct pressures between -500Pa and +1000Pa relative to atmosphere.
- Casing includes Pittsburg corner seams.

SECTIONAL SIZING AND JOINING FLANGE INFORMATION

- 35mm TDF flanges as standard or 40mm/50mm steel angle section frames may be provided on request.
- Rectangular attenuators will typically be made in a single piece up to a maximum of 2400mm in width, length or height. Above this dimension attenuators will be split into multiple sections in the dimension(s) exceeding the 2400mm limit noted.
- As a special request, attenuators may be divided into smaller sized sections than standard to fit through small spaces, before they are reassembled as a single unit on site.

CUSTOMISED ATTENUATOR OPTIONS

The following are available as special options when ordering Fantech's AirLay Rectangular Attenuators:

- Different materials of construction such as Stainless Steel Grades 304 and 316.
- Paints / protective coatings such as epoxy paint, Chlorinated Rubber etc.
- Flange material/dimensions profile can be specified e.g. Ductmate, TDF, Plain Steel Angle.

INSERTION LOSS

The values quoted in the tables are defined as static insertion loss as defined in BS4718:1971*, Methods of Test for Attenuators for Air Distribution System. Insertion losses greater than 50dB are not reported as their achievement in practice is difficult.

SUGGESTED SPECIFICATION

Rectangular attenuators shall be of the AirLay Series as designed and manufactured by Fantech Pty. Ltd. and shall have the dimensions, insertion losses and pressure losses as scheduled. Insertion Loss data for the attenuators will be derived from tests in accordance to BS4718:1971.

The casing shall be manufactured from Z275 coated galvanised sheet metal with Pittsburgh corner seams.

The acoustic infill shall be polyester made from 70% recycled material and will have a hardened outer membrane to reduce the potential for insulation fibres entering the airstream.

AIRLAY RECTANGULAR ATTENUATORS

HOW TO ORDER

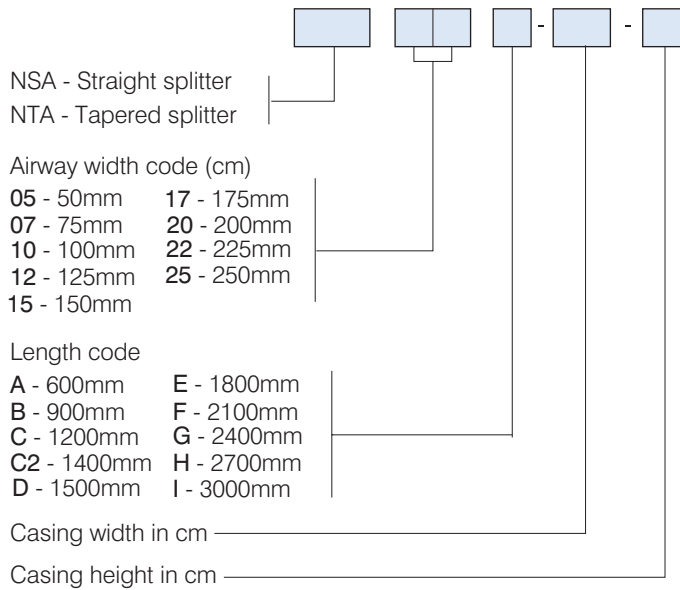

DIMENSIONS

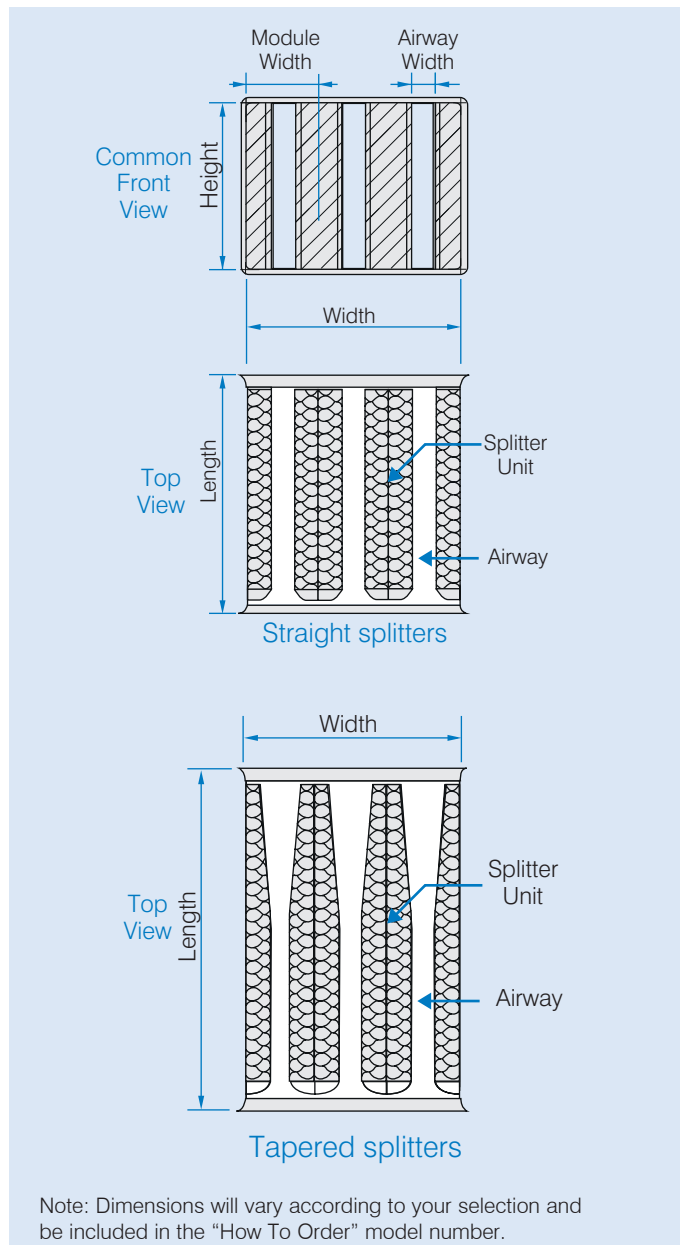

SELECTION PROCEDURE & PRESSURE DROP CALCULATION

Attenuators with small percentages of free area and longer length will provide the greatest attenuation but also the greatest pressure loss. Certain steps within the attenuator selection process may therefore need to be repeated a number of times in order to determine the best selection within these constraints.

The Fantech Selection Program can be used to quickly create multiple selection options or alternatively the following manual process can be used.

Step 1: Insertion Loss - From the performance data table select an attenuator that provides an insertion loss closest to that of the required insertion loss.

Step 2: Dimensions - Considering the dimensional constraints of the connecting duct work or installation location, select the most suitable set module width for the attenuator chosen in step one and nominate the required height (unrestricted).

Step 3: Face Velocity - Calculate the face velocity of the attenuator selected using the known air volume of the application and chosen width and height:

$$\text{Face Velocity (m/s)} = \frac{\text{Air Volume (m}^3\text{/s)}}{\text{Width (m) x Height (m)}}$$

Step 4: Pressure Drop Graphs - Locate the pressure drop graph which matches the length of the attenuator selection. Draw a line vertically from the calculated Face Velocity to where it intersects the chosen attenuator model. Draw a line horizontally from this point and where it intersects the vertical axis is the pressure drop for the chosen attenuator.

Example: A NTA10E attenuator with a calculated face velocity of 5m/s has been selected. The resulting pressure drop is 50Pa.

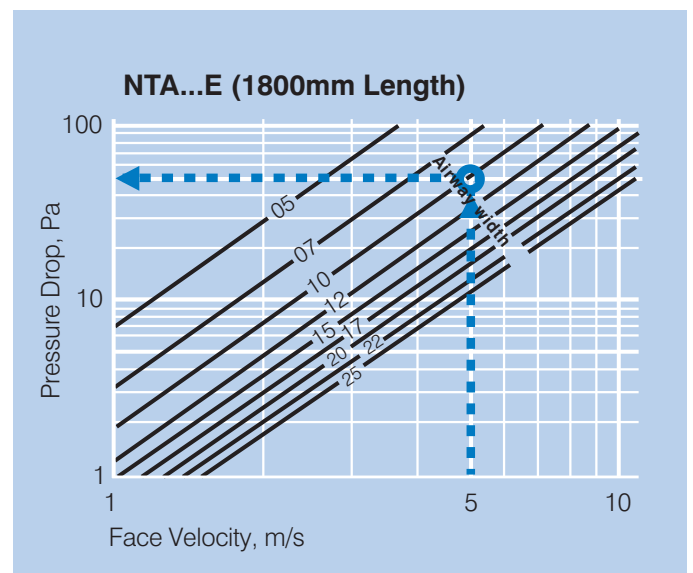

AIRLAY RECTANGULAR ATTENUATORS

TECHNICAL DATA – NTA ATTENUATOR, TAPERED SPLITTERS

Model No. NTA...	Length, (mm)	Static Insertion Loss, dB, Octave Band Centre Frequency (Hz)								Module Widths, mm.	
		63	125	250	500	1k	2k	4k	8k		
05C	1200	8	15	23	39	40	41	32	25	250*, 500, 750, 1000, 1250, 1500, 1750, 2000, 2250	
05C2	1400	9	18	28	43	44	46	34	28		
05E	1800	11	25	38	50	50	50	38	32		
05F	2100	12	29	45	50	50	50	44	36		
05G	2400	15	34	48	50	50	50	46	39		
05H	2700	16	39	50	50	50	50	50	43	Free Area 20%	
05I	3000	17	45	50	50	50	50	50	48		
07C	1200	7	14	21	29	35	35	26	23		275*, 550, 825, 1100, 1375, 1650, 1925, 2200
07C2	1400	8	16	25	34	40	40	29	25		
07E	1800	9	20	33	46	50	50	35	28		
07F	2100	11	24	40	48	50	50	41	31		
07G	2400	12	28	47	50	50	50	46	33		
07H	2700	13	34	49	50	50	50	50	36	Free Area 27%	
07I	3000	13	40	50	49	50	50	50	39		
10C	1200	7	12	19	26	29	29	23	20		300*, 600, 900, 1200, 1500, 1800, 2100, 2400
10C2	1400	8	14	22	32	34	34	26	21		
10E	1800	8	18	29	44	43	44	31	25		
10F	2100	9	20	34	47	50	49	35	27		
10G	2400	10	23	40	50	50	50	39	29		
10H	2700	11	27	46	50	50	50	44	31	Free Area 33%	
10I	3000	12	31	50	50	50	50	50	33		
12C	1200	7	12	17	23	25	26	21	17		325*, 650, 975, 1300, 1625, 1950, 2275
12C2	1400	7	13	20	29	30	30	23	18		
12E	1800	8	17	26	41	39	38	27	21		
12F	2100	9	19	31	45	47	43	30	23		
12G	2400	10	21	36	48	50	48	34	25		
12H	2700	10	25	41	50	50	50	38	26	Free Area 38%	
12I	3000	11	28	46	50	50	50	43	28		
15C	1200	7	12	15	21	21	22	18	15		350*, 700, 1050, 1400, 1750, 2100
15C2	1400	7	13	18	26	26	25	19	16		
15E	1800	7	16	23	37	37	32	23	18		
15F	2100	8	18	27	42	45	37	26	19		
15G	2400	9	20	32	47	50	42	29	20		
15H	2700	9	22	36	49	50	46	32	21	Free Area 43%	
15I	3000	9	24	40	50	50	50	36	22		
17C	1200	6	12	14	20	20	21	17	15		375*, 750, 1125, 1500, 1875, 2250
17C2	1400	7	13	17	25	24	24	18	16		
17E	1800	7	15	22	35	31	29	21	17		
17F	2100	7	17	26	40	37	33	24	18		
17G	2400	8	18	29	45	45	38	26	19		
17H	2700	8	20	33	48	50	41	29	20	Free Area 47%	
17I	3000	8	22	37	50	50	45	32	20		
20C	1200	6	12	13	18	19	19	16	16		400*, 800, 1200, 1600, 2000, 2400
20C2	1400	6	13	16	23	22	21	17	16		
20E	1800	6	15	20	32	28	26	19	17		
20F	2100	7	16	24	37	34	29	22	18		
20G	2400	7	17	27	43	38	33	24	18		
20H	2700	7	19	31	46	43	37	26	19	Free Area 50%	
20I	3000	7	20	34	50	47	40	29	19		
22C	1200	6	11	12	17	16	18	14	14		425*, 850, 1275, 1700, 2125
22C2	1400	6	12	14	21	19	20	15	14		
22E	1800	6	13	19	29	25	23	18	15		
22F	2100	6	15	22	34	30	27	20	16		
22G	2400	6	16	26	40	35	30	22	16		
22H	2700	6	17	29	44	39	33	24	17	Free Area 53%	
22I	3000	7	19	32	48	43	36	25	17		
25C	1200	5	10	11	15	14	17	12	11		450*, 900, 1350, 1800, 2250
25C2	1400	5	11	13	18	17	18	13	12		
25E	1800	6	12	17	26	21	21	16	13		
25F	2100	5	14	21	31	25	24	18	14		
25G	2400	5	15	24	37	29	27	20	14		
25H	2700	6	16	27	42	33	30	21	15	Free Area 56%	
25I	3000	6	18	30	46	37	32	22	15		

* Single module width, mm

AIRLAY RECTANGULAR ATTENUATORS

PRESSURE LOSS GRAPHS – NTA ATTENUATOR, TAPERED SPLITTERS

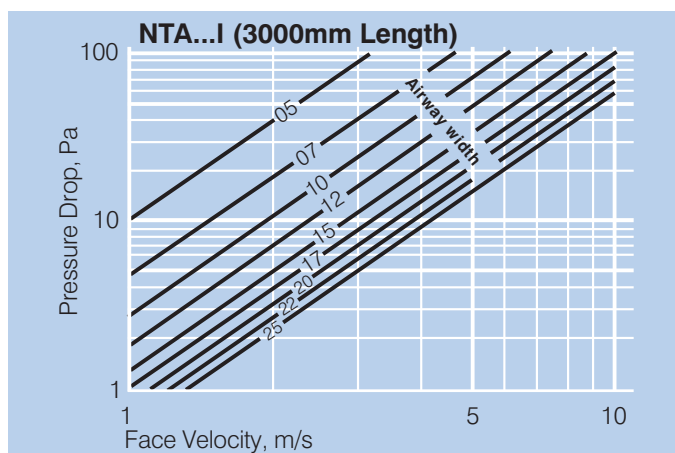
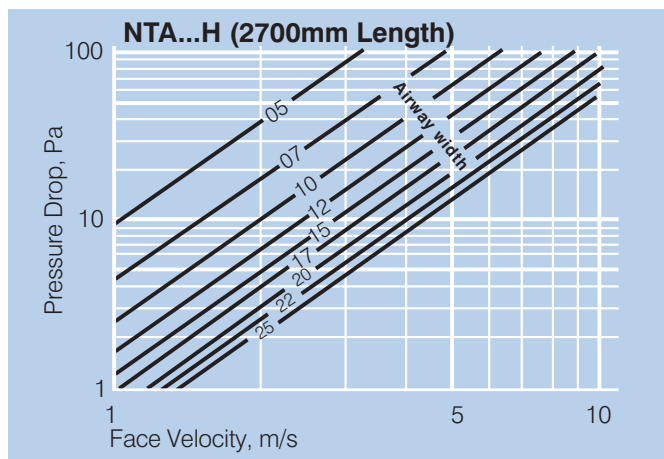
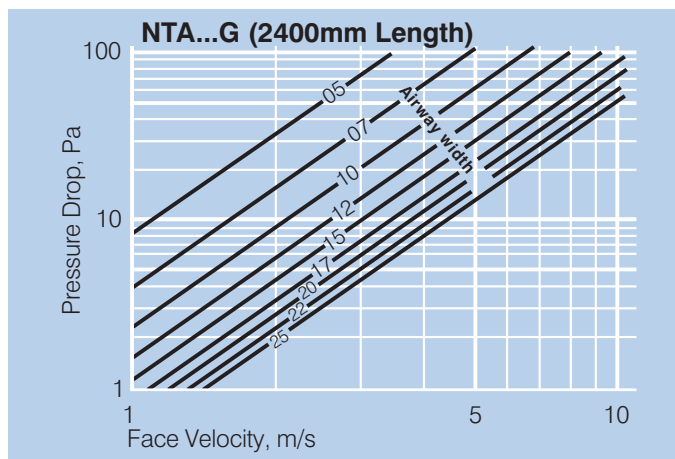
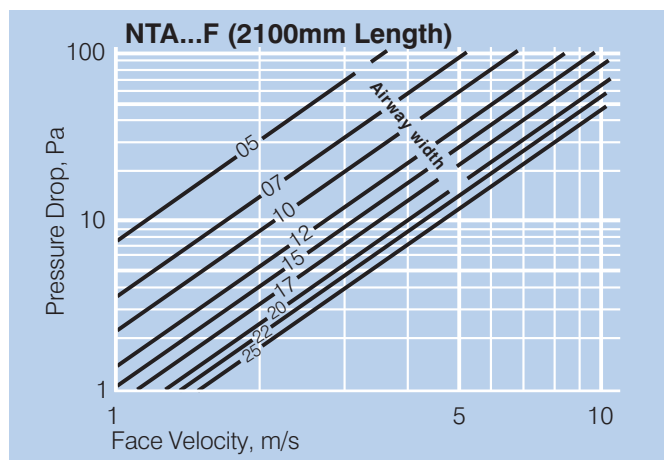
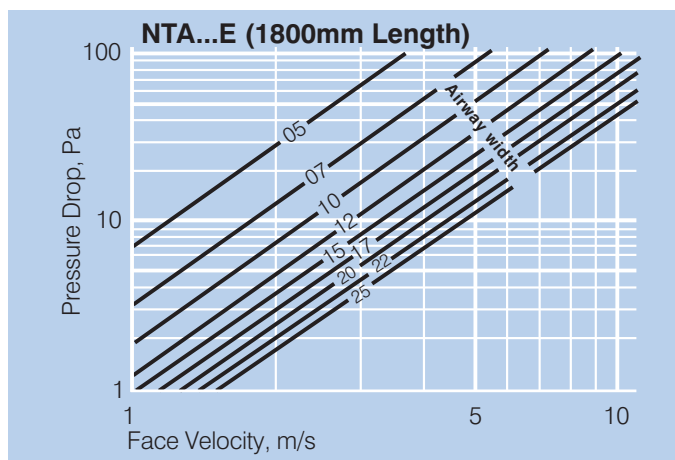
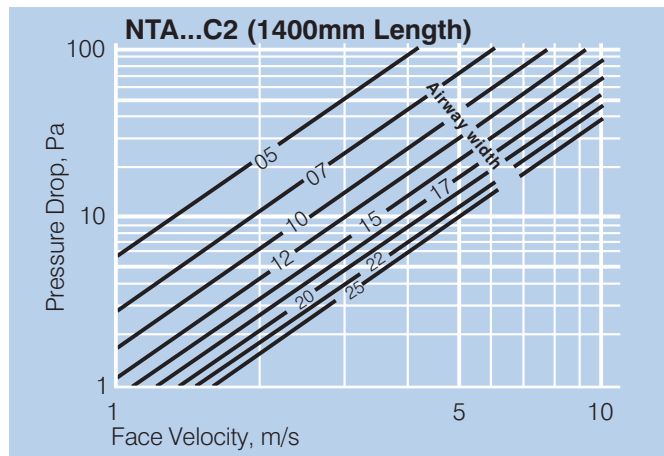
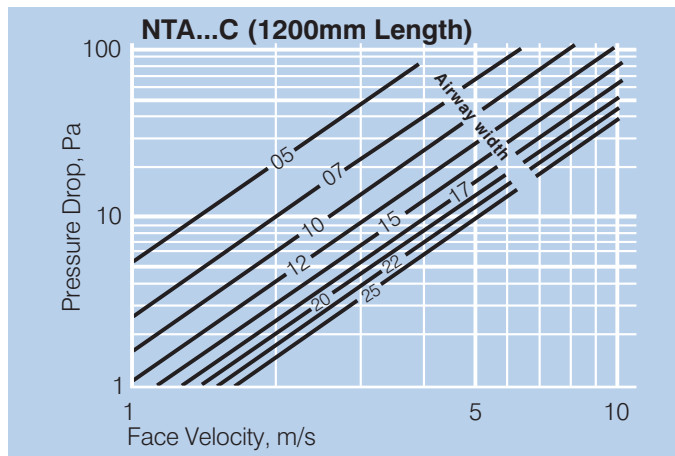

H

AIRLAY RECTANGULAR ATTENUATORS

TECHNICAL DATA – NSA ATTENUATOR, STRAIGHT SPLITTERS

Model No. NSA...	Length, (mm)	Static Insertion Loss, dB, Octave Band Centre Frequency (Hz)								Module Widths, mm.
		63	125	250	500	1k	2k	4k	8k	
05A	600	9	12	23	39	41	40	35	27	250*, 500, 750, 1000, 1250, 1500, 1750, 2000, 2250
05B	900	10	16	30	45	48	47	39	30	
05C	1200	11	21	38	50	50	50	43	34	
05C2	1400	12	24	43	50	50	50	46	37	
05E	1800	14	29	48	50	50	50	48	41	
05F	2100	16	33	50	50	50	50	50	45	
05G	2400	18	39	50	50	50	50	50	49	
07A	600	8	11	16	29	36	34	29	25	275*, 550, 825, 1100, 1375, 1650, 1925, 2200
07B	900	9	13	23	38	45	42	34	27	
07C	1200	9	16	30	47	50	50	40	30	
07C2	1400	10	19	35	48	50	50	43	32	
07E	1800	11	23	45	49	50	50	48	36	
07F	2100	13	28	47	50	50	50	50	38	
07G	2400	14	34	50	50	50	50	50	40	
10A	600	7	10	15	27	31	29	24	20	300*, 600, 900, 1200, 1500, 1800, 2100, 2400
10B	900	8	12	21	35	37	36	28	23	
10C	1200	9	14	27	44	46	44	36	26	
10C2	1400	10	16	31	46	49	48	39	27	
10E	1800	10	20	39	50	50	50	45	30	
10F	2100	11	23	45	50	50	50	46	32	
10G	2400	12	27	50	50	50	50	47	34	
12A	600	6	9	14	24	28	25	21	18	325*, 650, 975, 1300, 1625, 1950, 2275
12B	900	7	11	19	33	35	31	24	20	
12C	1200	8	13	24	41	41	37	30	22	
12C2	1400	9	15	28	44	45	40	32	23	
12E	1800	9	18	35	49	50	48	36	26	
12F	2100	10	21	40	50	50	50	39	28	
12G	2400	11	24	45	50	50	50	41	29	
15A	600	6	9	12	22	25	21	18	16	350*, 700, 1050, 1400, 1750, 2100
15B	900	6	10	17	30	33	26	20	17	
15C	1200	6	12	21	38	39	34	23	18	
15C2	1400	7	13	24	41	43	37	25	19	
15E	1800	8	16	31	48	50	44	29	22	
15F	2100	9	18	36	49	50	47	32	23	
15G	2400	10	20	40	50	50	49	35	24	
17A	600	5	8	12	20	24	21	16	16	375*, 750, 1125, 1500, 1875, 2250
17B	900	6	10	16	27	30	25	18	17	
17C	1200	6	12	20	35	38	32	21	17	
17C2	1400	7	13	23	38	41	35	22	18	
17E	1800	7	15	29	46	50	42	26	20	
17F	2100	8	17	33	48	50	45	29	21	
17G	2400	9	19	37	50	50	48	32	22	
20A	600	5	8	11	18	19	18	14	14	400*, 800, 1200, 1600, 2000, 2400
20B	900	5	10	15	25	24	22	16	16	
20C	1200	6	11	19	32	30	25	18	17	
20C2	1400	6	12	22	35	33	28	20	18	
20E	1800	6	14	26	43	40	32	23	18	
20F	2100	7	16	30	46	44	36	26	19	
20G	2400	8	17	34	50	50	40	28	20	
22A	600	5	8	10	17	18	16	13	14	425*, 850, 1275, 1700, 2125
22B	900	5	9	14	23	22	20	15	15	
22C	1200	6	11	18	29	26	23	17	16	
22C2	1400	6	12	20	33	29	25	18	16	
22E	1800	6	13	25	40	36	29	21	17	
22F	2100	7	15	28	44	40	32	23	17	
22G	2400	7	16	32	48	42	36	26	17	
25A	600	5	7	10	16	16	15	12	12	450*, 900, 1350, 1800, 2250
25B	900	5	9	13	21	20	19	14	13	
25C	1200	5	10	17	27	25	21	16	14	
25C2	1400	5	11	19	30	28	23	17	15	
25E	1800	6	12	23	37	32	26	19	15	
25F	2100	6	13	26	42	36	29	21	15	
25G	2400	7	15	29	46	40	32	23	15	

* Single module width, mm

AIRLAY RECTANGULAR ATTENUATORS

PRESSURE LOSS GRAPHS – NSA ATTENUATOR, STRAIGHT SPLITTERS

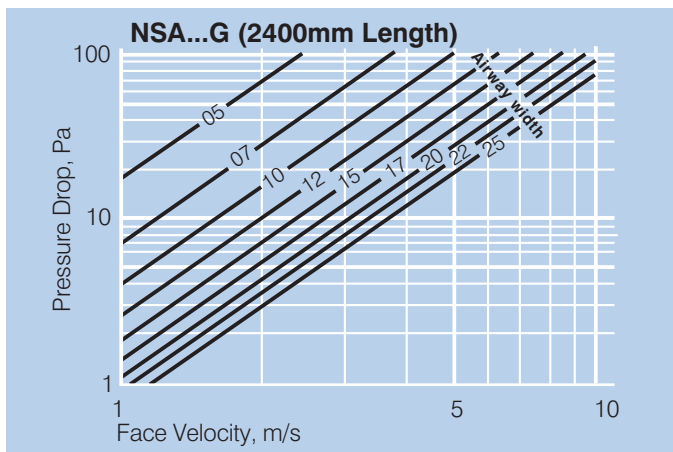
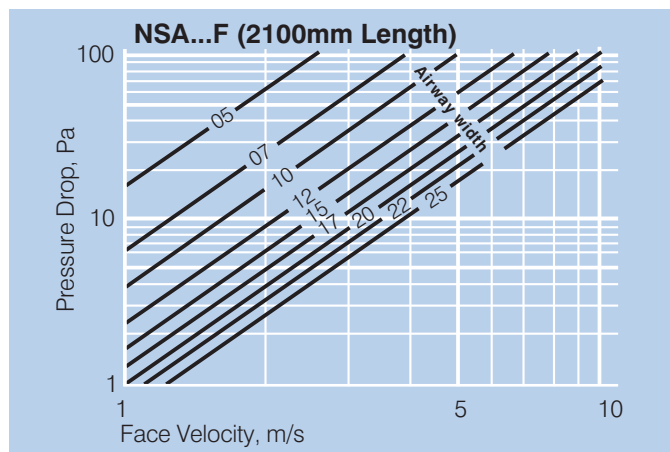
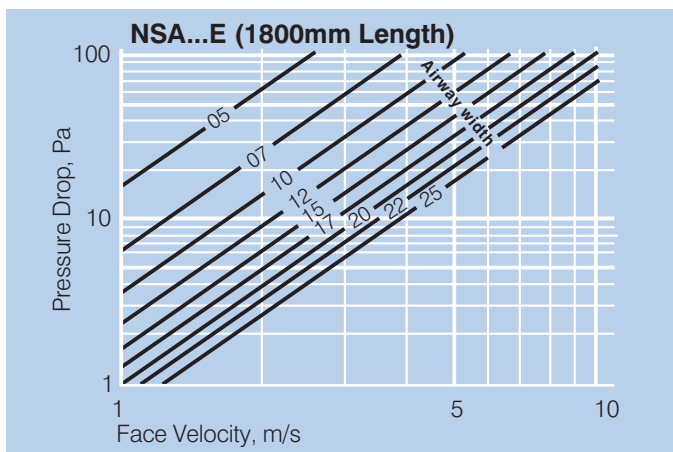
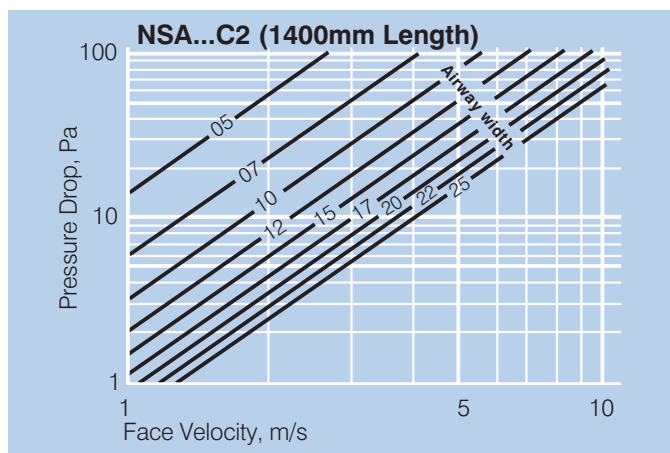
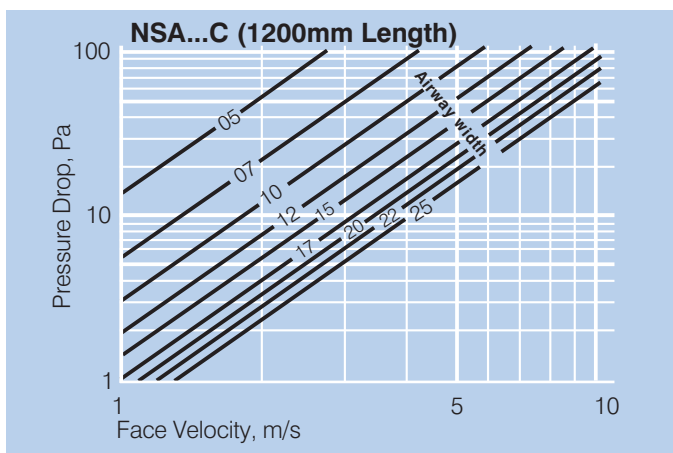
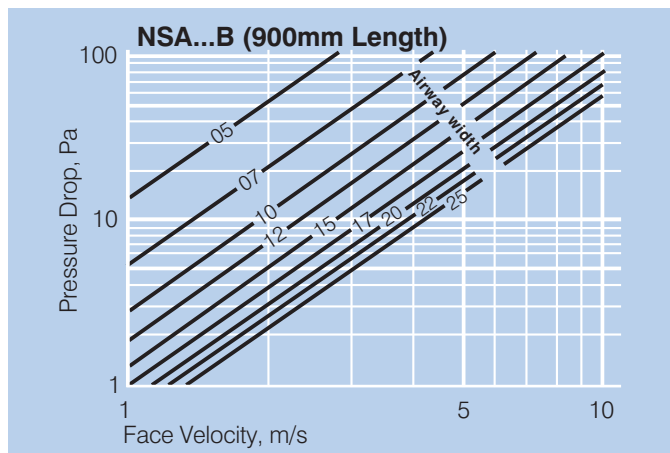
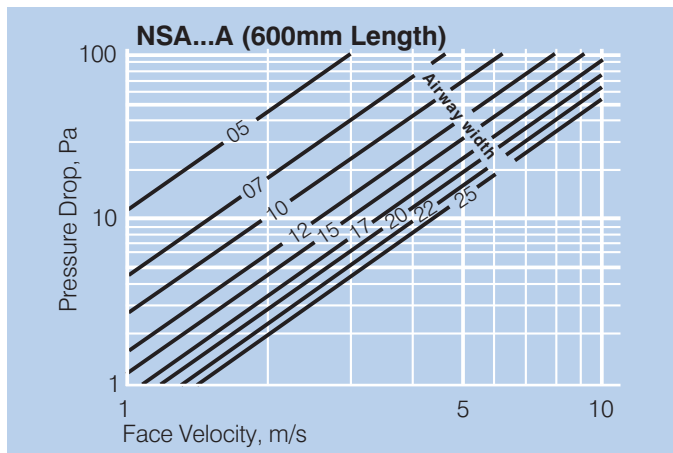

AIRLAY RECTANGULAR ATTENUATORS

HOW TO DETERMINE WEIGHT

Attenuator weights for individual models are available on the Fantech Selection Program or alternatively the following manual process can be used to attain the approximate maximum weight of each attenuator combination.

Divide the chosen attenuator width by the chosen module width to get the quantity of modules within the attenuator. Round up to the length and height row closest to the attenuator selected, and then the column with corresponding module quantity will provide the maximum weight of the selection. Interpolate for intermediate sizes as required.

NTA TAPERED - ATTENUATOR - WEIGHTS, KG*

Length, mm	Height, mm	Module Quantity							
		1	2	3	4	5	6	7	8
1200	600	37	58	86	114	143	156	169	182
	1200	64	97	137	178	218	243	268	293
	1800	91	134	186	237	352	388	424	460
	2400	118	174	237	364	436	484	532	580
1800	600	54	85	127	169	211	231	251	271
	1200	95	145	206	267	383	422	461	500
	1800	135	203	282	416	504	561	618	675
	2400	176	263	416	523	630	706	782	858
2400	600	72	115	171	228	285	313	341	369
	1200	126	193	275	357	493	546	599	652
	1800	180	272	379	540	656	734	812	890
	2400	234	351	537	678	819	922	1025	1128
3000	600	90	144	214	285	356	391	426	461
	1200	157	241	343	445	615	681	747	813
	1800	225	339	472	673	818	915	1012	1109
	2400	293	439	672	849	1025	1154	1283	1412

NSA STRAIGHT - ATTENUATOR - WEIGHTS, KG*

Length, mm	Height, mm	Module Quantity							
		1	2	3	4	5	6	7	8
600	600	22	34	51	67	84	92	100	108
	1200	37	55	77	100	123	137	151	165
	1800	52	77	107	137	166	187	208	229
	2400	67	98	134	169	205	232	259	286
1200	600	39	62	92	122	153	168	183	198
	1200	67	103	146	190	233	261	289	317
	1800	97	146	204	261	382	424	466	508
	2400	125	188	258	392	471	526	581	636
1800	600	57	91	136	181	226	249	272	295
	1200	99	153	218	283	403	446	489	532
	1800	140	213	297	436	529	591	653	715
	2400	182	275	434	547	660	742	824	906
2400	600	74	119	177	236	295	325	355	385
	1200	130	201	287	373	513	570	627	684
	1800	185	282	394	560	681	764	847	930
	2400	241	365	558	706	854	964	1074	1184

* Weights in the above tables are approximate. See the Fantech Selection Program for individual models.

